

 **WARNING**

To avoid unpredictable system behavior that can cause personal injury and property damage:

- Disconnect electrical supply (when necessary) before installation, servicing, or conversion.
- Disconnect air supply and depressurize all air lines connected to this product before installation, servicing, or conversion.
- Operate within the manufacturer's specified pressure, temperature, and other conditions listed in these instructions.
- Medium must be moisture-free if ambient temperature is below freezing.
- Service according to procedures listed in these instructions.
- Installation, service, and conversion of these products must be performed by knowledgeable personnel who understand how pneumatic products are to be applied.
- After installation, servicing, or conversion, air and electrical supplies (when necessary) should be connected and the product tested for proper function and leakage. If audible leakage is present, or the product does not operate properly, do not put into use.
- Warnings and specifications on the product should not be covered by paint, etc. If masking is not possible, contact your local representative for replacement labels.

 **CAUTION**

Polycarbonate bowls, being transparent and tough, are ideal for use with Filters and Lubricators. They are suitable for use in normal industrial environments, but should not be located in areas where they could be subjected to direct sunlight, an impact blow, nor temperatures outside of the rated range. As with most plastics, some chemicals can cause damage. Polycarbonate bowls should not be exposed to chlorinated hydrocarbons, ketones, esters and certain alcohols. They should not be used in air systems where compressors are lubricated with fire-resistant fluids such as phosphate ester and diester types.

Metal bowls are recommended where ambient and/or media conditions are not compatible with polycarbonate bowls. Metal bowls resist the action of most such solvents, but should not be used where strong acids or bases are present or in salt laden atmospheres. Consult the factory for specific recommendations where these conditions exist.

TO CLEAN POLYCARBONATE BOWLS USE MILD SOAP AND WATER ONLY! DO NOT use cleansing agents such as acetone, benzene, carbon tetrachloride, gasoline, toluene, etc., which are damaging to this plastic.

Introduction

Follow these instructions when installing, operating, or servicing the product.

Application Limits

These products are intended for use in general purpose compressed air systems only.

With Polycarbonate Bowl

	kPa	PSIG	bar
Operating Pressure Maximum	1034	150	10
Operating Temperature Range	40°F to 120°F (4°C to 49°C)		

With Zinc Bowl & Wrap Around Sight Gauge

	kPa	PSIG	bar
Operating Pressure Maximum	1723	250	17.0
Operating Temperature Range	40°F to 150°F (4°C to 66°C)		

With Aluminum Bowl

	kPa	PSIG	bar
Operating Pressure Maximum	2068	300	21
Operating Temperature Range	40°F to 180°F (4°C to 82°C)		

With Aluminum Bowl & Wrap Around Sight Gauge

	kPa	PSIG	bar
Operating Pressure Maximum	1034	150	10
Operating Temperature Range	40°F to 120°F (4°C to 49°C)		

ANSI Symbols

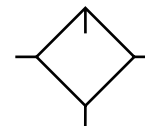

 **WARNING**

FAILURE OR IMPROPER SELECTION OR IMPROPER USE OF THE PRODUCTS AND/OR SYSTEMS DESCRIBED HEREIN OR RELATED ITEMS CAN CAUSE DEATH, PERSONAL INJURY AND PROPERTY DAMAGE.

This document and other information from The Company, its subsidiaries and authorized distributors provide product and/or system options for further investigation by users having technical expertise. It is important that you analyze all aspects of your application, including consequences of any failure and review the information concerning the product or systems in the current product catalog. Due to the variety of operating conditions and applications for these products or systems, the user, through its own analysis and testing, is solely responsible for making the final selection of the products and systems and assuring that all performance, safety and warning requirements of the application are met.

The products described herein, including without limitation, product features, specifications, designs, availability and pricing, are subject to change by The Company and its subsidiaries at any time without notice.

EXTRA COPIES OF THESE INSTRUCTIONS ARE AVAILABLE FOR INCLUSION IN EQUIPMENT / MAINTENANCE MANUALS THAT UTILIZE THESE PRODUCTS. CONTACT YOUR LOCAL REPRESENTATIVE.

L606 Lubricator Installation

IS-L606

- The lubricator should be installed with reasonable accessibility for service whenever possible – repair service kits are available. Keep pipe or tubing lengths to a minimum with inside clean and free of dirt and chips. Pipe joint compound should be used sparingly and applied only to the male pipe – never into the female port. Do not use PTFE tape to seal pipe joints – pieces have a tendency to break off and lodge inside the unit, possibly causing malfunction. Also, new pipe or hose should be installed between the lubricator and equipment being lubricated.
- The upstream pipe work must be clear of accumulated dirt and liquids.
- Select a lubricator location as close as possible to the equipment being lubricated and downstream of any pressure regulator.
- Install lubricator so that air flows in the direction of arrow on body.
- Install lubricator vertically with bowl drain mechanism (if supplied) at the bottom.

Operation and Service

- Filling — Lubricators can be filled while under pressure and without shutting down equipment. Slowly remove either fill plug and fill to 1/4" to top of bowl using correct oil. For proper automatic fill operation, the oil inlet pressure to lubricator must be maintained between 10 and 200 PSI above air pressure to lubricator.

Suggested Lubricant: F442

Petroleum based oil of 100 to 200 SSU viscosity at 100°F and an aniline point greater than 200°F. (Mobil DTE24 and Sun Company Sunvis 932 are good examples). Do not use oils with adhesives, compound oils containing solvents, graphite, detergents or synthetic oils.

- Replace the Fill Plug (by turning clockwise) and seat firmly. Excessive torque is not required. Turn on air supply, if leakage occurs, **DO NOT OPERATE** — conduct repairs again. The lubricator is now ready for setting.
- Oil Delivery Adjustment — To adjust oil delivery, turn Adjustment Knob on top of the lubricator.

Leaner — Clockwise

Richer — Counterclockwise

By counting the number of drops per minute in the Sight Dome, you can adjust to your requirements. Generally, one drop per minute downstream for every 10 - 15 SCFM flow is satisfactory. 25 drops per minute equals one (1) ounce per hour - volume of oil passing through the Sight Dome.

NOTE: This is a constant density type lubricator which delivers a constant ratio of oil air flow. Therefore, if air flow increases or decreases, oil delivery will be adjusted proportionately. **ONLY IF A DIFFERENT RATIO IS DESIRED SHOULD YOUR ADJUSTMENT KNOB SETTING BE CHANGED AFTER YOUR INITIAL SETTING.**

- Cleaning — Erratic lubricator operation or loss of lubrication is almost always due to dirt (rust, pipe tape, etc.) in the needle valve or venturi area. To clean, shut off and vent all air line pressure to the unit being cleaned. In most cases cleaning is needed only in the oil metering area. Pull off Adjusting Knob and remove Needle Valve Assembly by turning out large hex nut. Remove Needle Valve Seat and clean removed parts with alcohol making sure hole in seat is clear. With a #57 drill, make sure hole in bottom of sight gauge area is open. Remove Bowl. Clean parts with soapy water or denatured alcohol **but do not use denatured alcohol on plastic bowl, sight dome or sight gauge.** If using compressed air to blow dry, be sure to wear appropriate eye protection.
- After servicing, apply system pressure and check for air leaks. If leakage occurs, **Do Not Operate** — conduct servicing again.

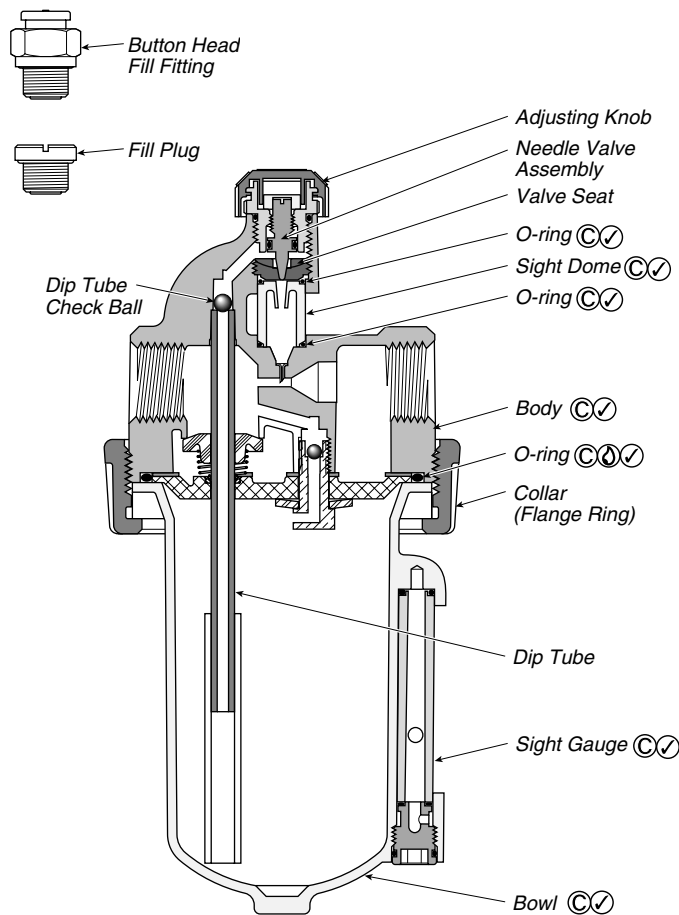

- Lightly grease with provided lubricant.
- Inspect for nicks, scratches, and surface imperfections. If present, reduced service life is probable and future replacement should be planned.
- Clean with lint-free cloth.

Kits Available

Description	Product Number	Bowl Type	Port Size
Bowl			
Polycarbonate	BK606Y	B	1/4", 3/8"
Zinc with Sight Gauge	BK609WY	W	1/4", 3/8"
Polycarbonate	BK606A	B	1/2"
Aluminum	BK603A	E	1/2"
Zinc with Sight Gauge	BK609WA	W	1/2"
Aluminum with Sight Gauge	BK606X30A	G	1/2"
Aluminum	BK603B	E	3/4" thru 1-1/2"
Zinc with Sight Gauge	BK609WB	W	3/4" thru 1-1/2"
Aluminum with Sight Gauge	BK606X30B	G	3/4" thru 1-1/2"
Repair Kit			
Dip Tube Replacement Kit	DTK606	All	All Sizes
Needle Valve Assembly	RK606Y	All	All Sizes
Sight Dome Repair Kit	RK606SY	All	All Sizes
Sight Gauge Bowl Repair Kit	RBK605WY	W	1/4", 3/8"
Sight Gauge Bowl Repair Kit	RKB605WA	W	1/2"
Sight Gauge Bowl Repair Kit	RKB606X30A	G	1/2"
Sight Gauge Bowl Repair Kit	RKB606WB	W	3/4" thru 1-1/2"
Sight Gauge Bowl Repair Kit	RKB606X30B	G	3/4" thru 1-1/2"
Button Head Fill Fitting	SAA606C109-1	—	—
Fill Plug	SA60684	—	—