

**⚠ WARNING**

To avoid unpredictable system behavior that can cause personal injury and property damage:

- Disconnect electrical supply (when necessary) before installation, servicing, or conversion.
- Disconnect air supply and depressurize all air lines connected to this product before installation, servicing, or conversion.
- Operate within the manufacturer's specified pressure, temperature, and other conditions listed in these instructions.
- Medium must be moisture-free if ambient temperature is below freezing.
- Service according to procedures listed in these instructions.
- Installation, service, and conversion of these products must be performed by knowledgeable personnel who understand how pneumatic products are to be applied.
- After installation, servicing, or conversion, air and electrical supplies (when necessary) should be connected and the product tested for proper function and leakage. If audible leakage is present, or the product does not operate properly, do not put into use.
- Warnings and specifications on the product should not be covered by paint, etc. If masking is not possible, contact your local representative for replacement labels.

**Safety Guide**

For more complete information on recommended application guidelines, see the Safety Guide section of Pneumatic Division catalogs or you can download the **Pneumatic Division Safety Guide** at: [www.wilkersoncorp.com](http://www.wilkersoncorp.com)

**Introduction**

Follow these instructions when installing, operating, or servicing the product.

**Application Limits**

These products are intended for use in general purpose compressed air systems only.

Operating Pressure Maximum	kPa	PSIG	bar
Bowl w/ Twist Drain / No Sight Gauge	2068	300	21.0
Bowl w/ Twist Drain and Sight Gauge	1700	250	17.0

**Operating Temperature Ratings –**

**Metal Bowl w/o Sight Gauge** 0°F to 150°F (-18°C to 66°C)

**Metal Bowl w/ Sight Gauge** 0°F to 150°F (-18°C to 66°C)

**Note:** Air must be dry enough to avoid ice formation at temperatures below 32°F (0°C).

**Symbol**

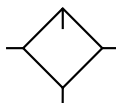

Lubricator  
w/ Manual Drain

**Installation**

1. The lubricator should be installed with reasonable accessibility for service whenever possible. Keep pipe or tubing lengths to a minimum with inside clean and free of dirt and chips. Pipe joint compound should be used sparingly and applied only to the male pipe – never into the female port. Do not use PTFE tape to seal pipe joints – pieces have a tendency to break off and lodge inside the unit, possibly causing malfunction.
2. Install lubricator so air flows into port labelled “IN” on body.
3. Installation should be upstream of the device it is to lubricate (valve, cylinders, tool, etc.) as possible.

**Service Kits Available**

Description	L10 (1/2")
Drip Control Kit	PS740N
Sight Gauge Kit	SA607Y103-2-SS
Bowl Seal	F10Y103-2VT

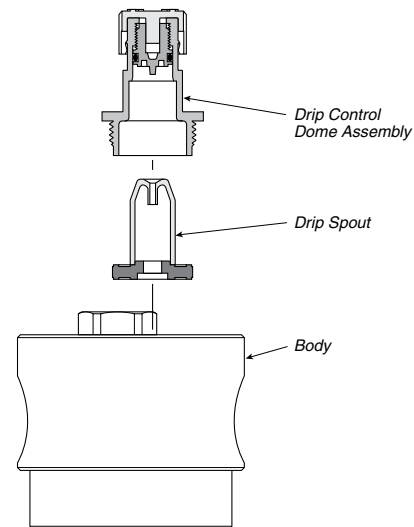

**⚠ WARNING**

**FAILURE OR IMPROPER SELECTION OR IMPROPER USE OF THE PRODUCTS AND/OR SYSTEMS DESCRIBED HEREIN OR RELATED ITEMS CAN CAUSE DEATH, PERSONAL INJURY AND PROPERTY DAMAGE.**

This document and other information from The Company, its subsidiaries and authorized distributors provide product and/or system options for further investigation by users having technical expertise. It is important that you analyze all aspects of your application, including consequences of any failure and review the information concerning the product or systems in the current product catalog. Due to the variety of operating conditions and applications for these products or systems, the user, through its own analysis and testing, is solely responsible for making the final selection of the products and systems and assuring that all performance, safety and warning requirements of the application are met.

The products described herein, including without limitation, product features, specifications, designs, availability and pricing, are subject to change by The Company and its subsidiaries at any time without notice.

**EXTRA COPIES OF THESE INSTRUCTIONS ARE AVAILABLE FOR INCLUSION IN EQUIPMENT / MAINTENANCE MANUALS THAT UTILIZE THESE PRODUCTS. CONTACT YOUR LOCAL REPRESENTATIVE.**

### Operation and Service

**⚠ Caution: Shut off air supply and exhaust the pressure trapped within the lubricator before filling unit.**

1. Remove the fill plug and fill the lubricator with the suggested lubricant.

Suggested lubricant: F442

Petroleum based oil of 100 to 200 SSU viscosity at 100°F and an aniline point greater than 200°F. (Mobil DTE24 and Sun Company Sunvis 932 are good examples). Do not use oils with adhesives, compound oils containing solvents, graphite, detergents or synthetic oils.

2. Replace the fill plug (by turning clockwise) and seat firmly. Excessive torque is not required. If leakage occurs, **DO NOT OPERATE** — check to make sure the fill plug is installed properly. The lubricator is now ready for setting.
3. Oil delivery adjustment — To adjust oil delivery, turn adjustment knob on top of the lubricator.

Leaner — Clockwise

Richer — Counterclockwise

By counting the number of drops per minute in the sight dome, you can adjust to your requirements.

Every drop visible in the sight dome goes downstream.

Generally, one drop per minute downstream for every 10 - 15 SCFM flow is satisfactory.

25 drops per minute equals one (1) ounce per hour - volume of oil passing through the sight dome.

**NOTE:** This is a constant density type lubricator which delivers a constant ratio of oil to air flow. Therefore, if air flow increases or decreases, oil delivery will be adjusted proportionately. **ONLY IF A DIFFERENT RATIO IS DESIRED SHOULD YOUR ADJUSTMENT KNOB SETTING BE CHANGED AFTER YOUR INITIAL SETTING.**

4. To replace fill plug, drip control, & service lubricator:
  - A. Turn off air supply and depressurize the unit.
  - B. Refer to pictorial for servicing and torque values.
  - C. Turn on air supply and check lubricator for leakage. If leakage occurs, **DO NOT OPERATE** — conduct repairs again.

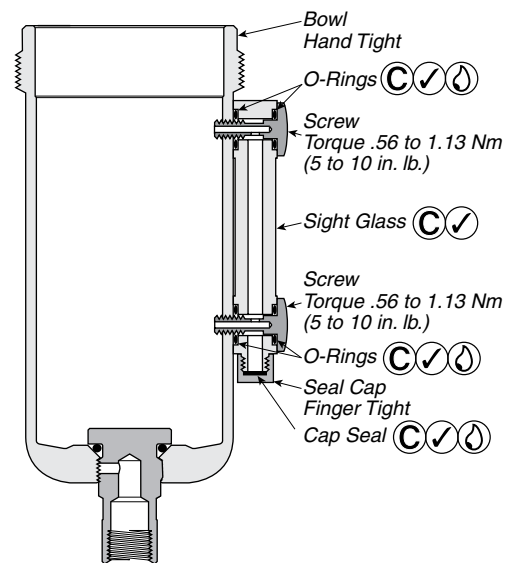
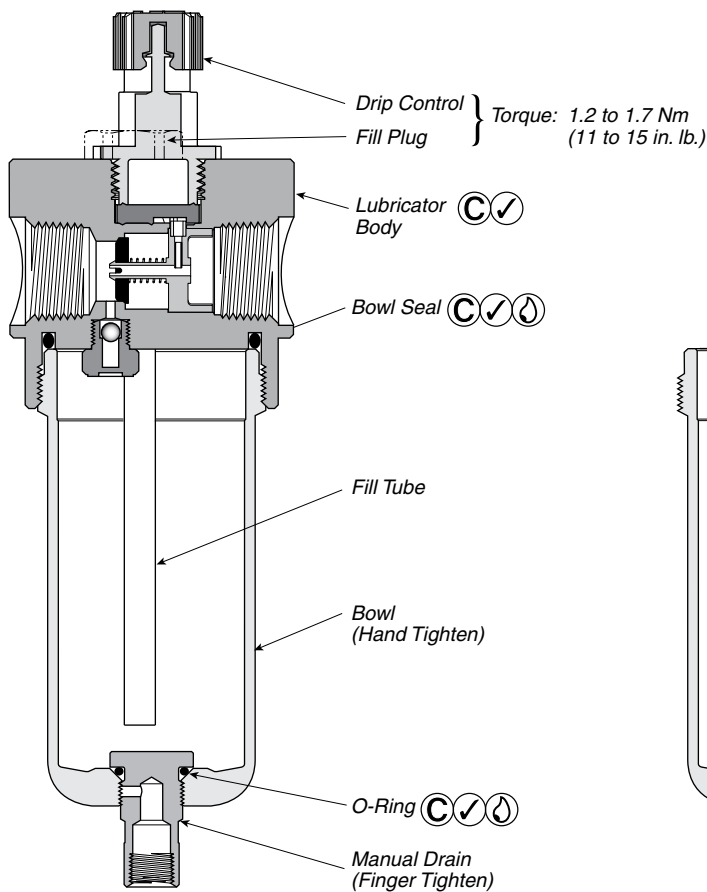

**L10 Metal Bowl With Sight Gauge**

- ☽ Lightly grease with provided lubricant.
- ✓ Inspect for nicks, scratches, and surface imperfections. If present, reduced service life is probable and future replacement should be planned.
- Ⓒ Clean with lint-free cloth.