

⚠ WARNING

- To avoid unpredictable system behavior that can cause personal injury and property damage:
- Disconnect electrical supply (when necessary) before installation, servicing, or conversion.
 - Disconnect air supply and depressurize all air lines connected to this product before installation, servicing, or conversion.
 - Operate within the manufacturer's specified pressure, temperature, and other conditions listed in these instructions.
 - Medium must be moisture-free if ambient temperature is below freezing.
 - Service according to procedures listed in these instructions.
 - Installation, service, and conversion of these products must be performed by knowledgeable personnel who understand how pneumatic products are to be applied.
 - After installation, servicing, or conversion, air and electrical supplies (when necessary) should be connected and the product tested for proper function and leakage. If audible leakage is present, or the product does not operate properly, do not put into use.
 - Warnings and specifications on the product should not be covered by paint, etc. If masking is not possible, contact your local representative for replacement labels.

Safety Guide

For more complete information on recommended application guidelines, see the Safety Guide section of Pneumatic Division catalogs or you can download the **Pneumatic Division Safety Guide** at: www.parker.com/pneumatics

Introduction

Follow these instructions when installing, operating, or servicing the product.

Application Limits

These products are intended for use in general purpose compressed air systems only.

Maximum Recommended Pressure Drop:

	kPa	PSIG	bar
Particulate Filter	70	10	0.7
Operating Pressure Maximum	kPa	PSIG	bar
Bowl w/ Twist Drain / No Sight Gauge	2068	300	21.0
Bowl w/ Auto Drain / No Sight Gauge	1210	175	12.1
Bowl w/ Twist Drain and Sight Gauge	1700	250	17.0
Bowl w/ Auto Drain and Sight Gauge	1210	175	12.1

Operating Temperature Range:

F504 –	
Manual Twist Drain	0°F to 180°F (-18°C to 82°C)
Auto Pulse Drain	32°F to 150°F (0°C to 66°C)
F10 –	
Manual Twist Drain (D)	0°F to 180°F (-18°C to 82°C)
Manual Twist Drain (W)	0°F to 150°F (-18°C to 66°C)
Automatic Float Drain	32°F to 150°F (0°C to 66°C)

Standard Size Low Temperature Operating Temperature: -40°C/F
 Note: Air must be dry enough to avoid ice formation at temperatures below 32°F (0°C).

Symbols

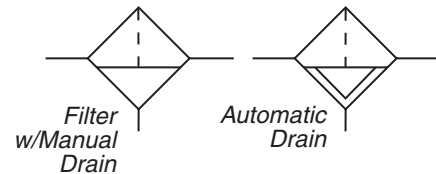

Installation

1. The filter should be installed with reasonable accessibility for service whenever possible – repair service kits are available. Keep pipe or tubing lengths to a minimum with inside clean and free of dirt and chips. Pipe joint compound should be used sparingly and applied only to the male pipe – never into the female port. Do not use PTFE tape to seal pipe joints – pieces have a tendency to break off and lodge inside the unit, possibly causing malfunction. Also, new pipe or hose should be installed between the filter and equipment being protected.
2. The upstream pipe work must be clear of accumulated dirt and liquids.
3. Select a filter location as close as possible to the equipment being protected and upstream of any pressure regulator.
4. Install filter so that air flows into port labelled “IN” on body.
5. Install filter vertically with bowl drain mechanism at the bottom. Free moisture will thus drain into the sump “quiet zone” at the bottom of the bowl.

⚠ WARNING

FAILURE OR IMPROPER SELECTION OR IMPROPER USE OF THE PRODUCTS AND/OR SYSTEMS DESCRIBED HEREIN OR RELATED ITEMS CAN CAUSE DEATH, PERSONAL INJURY AND PROPERTY DAMAGE.

This document and other information from The Company, its subsidiaries and authorized distributors provide product and/or system options for further investigation by users having technical expertise. It is important that you analyze all aspects of your application, including consequences of any failure and review the information concerning the product or systems in the current product catalog. Due to the variety of operating conditions and applications for these products or systems, the user, through its own analysis and testing, is solely responsible for making the final selection of the products and systems and assuring that all performance, safety and warning requirements of the application are met.

The products described herein, including without limitation, product features, specifications, designs, availability and pricing, are subject to change by The Company and its subsidiaries at any time without notice.

EXTRA COPIES OF THESE INSTRUCTIONS ARE AVAILABLE FOR INCLUSION IN EQUIPMENT / MAINTENANCE MANUALS THAT UTILIZE THESE PRODUCTS. CONTACT YOUR LOCAL REPRESENTATIVE.

Operation

- Both free moisture and solids are removed automatically by the filter.
- Manual drain filters must be drained regularly before the separated moisture and oil reaches the bottom of the baffle or end cap.
- The filter element should be removed and replaced when pressure differential across the filter is 69 kPa (10 PSIG).

Service Procedure

⚠ Caution: Shut off air supply and exhaust the pressure trapped within the filter bowl before servicing unit.

- Unscrew and remove bowl.
- Unscrew the filter holder from body and then remove element.
- Clean all internal parts and bowl before reassembling.
- Element should be replaced if soiled or creating excessive pressure drop. **IMPORTANT:** The filter will not operate properly if the deflector is not installed properly. The deflector must be installed between the filter stem and the filter body.
- Attach filter holder and finger tighten firmly.
- Replace bowl seal. Lightly lubricate new seal to assist with retaining it in position.
- Install bowl into body and tighten; hand tight, plus 1/4 turn.
- After servicing, apply system pressure and check for air leaks. If leakage occurs, **DO NOT Operate** — conduct servicing again.

Service Kits Available

Description	Miniature (1/4")	Standard (1/2")
Auto Drain	—	SA10MDSS
Auto Pulse Drain	RKP05482-SS	—
Element (5 Micron)	EK504VY	EK55G
Element (20 Micron)	EK504Y	—
Element (40 Micron)	—	EK55J
Manual Drain	SAP05481	SAP05481
Sight Gauge Kit	—	SA607Y103-2SS
Bowl Seal	GSK-504Z101-1VT	F10Y103-2VT

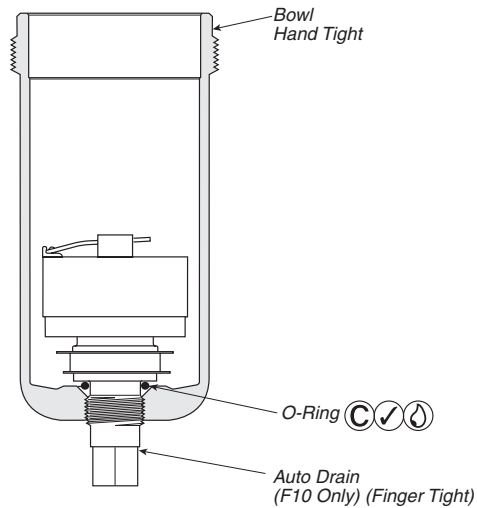

Standard (1/2") Metal Bowl with Auto Drain

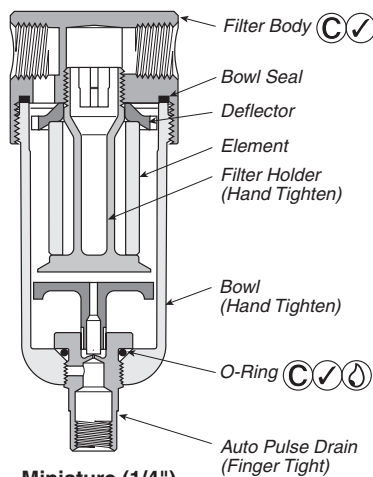

Miniature (1/4") Particulate Filter

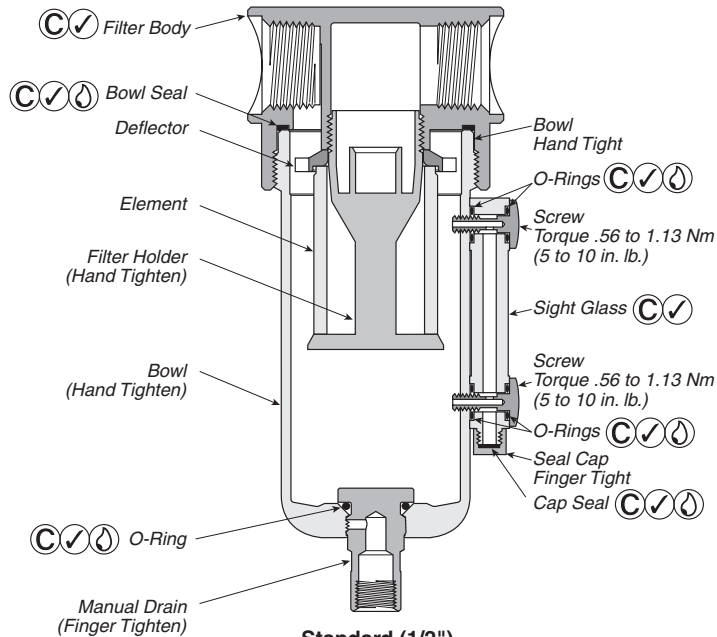

Standard (1/2") Metal Bowl with Sight Gauge

- Lightly grease with provided lubricant.
- Inspect for nicks, scratches, and surface imperfections. If present, reduced service life is probable and future replacement should be planned.
- Clean with lint-free cloth.