

**⚠ WARNING**

To avoid unpredictable system behavior that can cause personal injury and property damage:

- Disconnect electrical supply (when necessary) before installation, servicing, or conversion.
- Disconnect air supply and depressurize all air lines connected to this product before installation, servicing, or conversion.
- Operate within the manufacturer's specified pressure, temperature, and other conditions listed in these instructions.
- Medium must be moisture-free if ambient temperature is below freezing.
- Service according to procedures listed in these instructions.
- Installation, service, and conversion of these products must be performed by knowledgeable personnel who understand how pneumatic products are to be applied.
- After installation, servicing, or conversion, air and electrical supplies (when necessary) should be connected and the product tested for proper function and leakage. If audible leakage is present, or the product does not operate properly, do not put into use.
- Warnings and specifications on the product should not be covered by paint, etc. If masking is not possible, contact your local representative for replacement labels.

**Introduction**

Follow these instructions when installing, operating, or servicing the product.

**Application Limits**

These products are intended for use in general purpose compressed air systems only.

**Operating Inlet Pressure:**

	<b>kPa</b>	<b>PSIG</b>	<b>bar</b>
with Polycarbonate Bowl	1000	150	10.3
with Metal Bowl	1700	250	17.0

**NOTE:** The maximum recommended pressure drop for a particulate filter is 70 kPa (10 psig, 0.7 bar)

**Ambient Temperature Range:**

with Polycarbonate Bowl	0°C to 52°C (32°F to 125°F)
with Metal Bowl	0°C to 80°C (32°F to 175°F)

**Symbols**

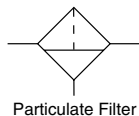
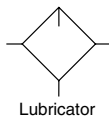

**Mist Lubricators (Figure 1)**

**Description**

These mist lubricators are designed to deliver an atomized oil mist to air operated tools, motors, and other pneumatic equipment. Units are equipped with full-view sight glass for visual indication of oil drop rate, needle valve feed adjustment to regulate oil drop rate, and a venturi bypass disc to compensate for changes in air flow demands.

**Installation of Lubricator**

1. Lubricator should be installed with reasonable accessibility for service whenever possible - repair service kits are available. Keep pipe and tubing lengths to a minimum with inside clean and free of dirt and chips. Pipe joint compounds should be used sparingly and applied only to the male pipe - never into the female port. Do not use PTFE tape to seal pipe joints - pieces have a tendency to break off and lodge inside the unit, possibly causing malfunction.

2. Install lubricator so that air flow is in the direction of arrow on body.
3. Installation should be upstream from, and as close as possible, to the device it is to lubricate (valve, cylinder, tool, etc.). Whenever possible, avoid locations that require air-borne oil to move in an upward direction to reach the device to be lubricated.
4. The installation of an individual lubricator for each air consuming device provides best assurances of proper lubrication.
5. In new installations, it is good practice to "wet down" the inside diameter of piping and/hose with oil before making final connections. Although your lubricator delivers oil to the line, pre-coating the inside diameter with oil helps insure that proper amounts of oil are delivered to the point of application.

**Operation & Service of Lubricator**

**⚠ Warning: Before filling, inlet pressure must be eliminated and then de-pressurize system pressure.**

1. **FILLING** - After de-pressurizing system, remove bowl to refill lubricator. Fill bowl to fill line indicated on the bowl with oil of 150 to 200 SSU at 100°F viscosity - same as SAE No. 10 (petroleum based hydraulic oils or spindle oils are good examples). **DO NOT USE OILS WITH TACKY ADDITIVES, COMPOUND OILS CONTAINING SOLVENTS, GRAPHITE, SOAPS OR DETERGENTS.** (Automotive oils generally contain detergents and are not recommended.)
2. Replace the bowl and seat firmly. Excessive torque is not necessary. The lubricator is now ready for setting.
3. **OIL DELIVERY ADJUSTMENT** - To adjust oil delivery, turn the adjusting needle on top of the lubricator.

Leaner - Clockwise      Richer - Counterclockwise

By counting the number of drops per minute in the sight dome, you can adjust lubricator to your required setting.

Generally, one drop per minute downstream for every 10-15 SCFM flow is satisfactory. 25 drops per minute equals one ounce per hour - volume of oil passing through the sight dome.

**NOTE:** This is a constant density type lubricator which delivers a constant ratio of oil to air flow. Therefore, if air flow increases or decreases, oil delivery will be effected proportionately. **ONLY IF DIFFERENT RATIO IS DESIRED SHOULD YOUR ADJUSTMENT KNOB SETTING BE CHANGED AFTER YOUR INITIAL SETTING.**

**⚠ WARNING**

**FAILURE OR IMPROPER SELECTION OR IMPROPER USE OF THE PRODUCTS AND/OR SYSTEMS DESCRIBED HEREIN OR RELATED ITEMS CAN CAUSE DEATH, PERSONAL INJURY AND PROPERTY DAMAGE.**

This document and other information from The Company, its subsidiaries and authorized distributors provide product and/or system options for further investigation by users having technical expertise. It is important that you analyze all aspects of your application, including consequences of any failure and review the information concerning the product or systems in the current product catalog. Due to the variety of operating conditions and applications for these products or systems, the user, through its own analysis and testing, is solely responsible for making the final selection of the products and systems and assuring that all performance, safety and warning requirements of the application are met.

The products described herein, including without limitation, product features, specifications, designs, availability and pricing, are subject to change by The Company and its subsidiaries at any time without notice.

**EXTRA COPIES OF THESE INSTRUCTIONS ARE AVAILABLE FOR INCLUSION IN EQUIPMENT / MAINTENANCE MANUALS THAT UTILIZE THESE PRODUCTS. CONTACT YOUR LOCAL REPRESENTATIVE.**

**Service Kits - Lubricator**

Kit#	Description
PS420	Polycarbonate Bowl with Manual Drain - consists of items: 18 (open bottom), 15, 16 & 17
PS421	Polycarbonate Bowl without Drain - consists of items: 18 (closed bottom) & 15
PS740	Drip Control (Polycarbonate)
PS740N	Drip Control (Nylon)

**Parts Identification List - Lubricator**

Item#	Description	Item#	Description
1	Knob	10	Ball, Check
2	Drip Control Body	11	Spring
3	Needle	12	Ball, Check
4	O-ring	13	Body
5	Drip Tube	14	Tube
6	Seal Plate	15	O-ring (Body to Bowl)
7	O-ring	16	Twist Drain
8	By-pass Plate	17	O-ring (Drain)
9	By-pass	18	Bowl

**Particulate Filter (Figure 2)**

**Description**

These air line filters are heavy-duty units used to remove airborne impurities from air supply lines by means of centrifugal force and filter element. Units are equipped with vane-type deflectors and drain valves. Deflector plate creates swirling action to the air stream assuring entrainment separation at all flow rates. Filter element with extra large surface assures fine filtration with low pressure drop. Turn manual drain counterclockwise to open and clockwise to close.

**Installation of Filter**

1. Filter should be installed with reasonable accessibility for service whenever possible - repair service kits are available. Keep pipe and tubing lengths to a minimum with inside clean and free of dirt and chips. Pipe joint compounds should be used sparingly and applied only to the male pipe - never into the female port. Do not use PTFE tape to seal pipe joints - pieces have a tendency to break off and lodge inside the unit, possibly causing malfunction.
2. Install unit so that air flow is in the direction of arrow. Installation must be upstream of and close to devices it is to service (valve, cylinder, tool, etc.). Position unit vertically with the bowl drain mechanism at the bottom. Free moisture will thus drain into the sump ("quiet zone") at the bottom of the bowl.

**Operation of the Filter**

1. Both free moisture and solids are removed automatically by the filter.
2. Manual drain filters must be drained regularly before the separated moisture and oil reaches the bottom of the element holder. Automatic drain models (pulse drain) will collect and dump liquids automatically. They are actuated when a pressure drop occurs within the filter.
3. The filter element should be removed and replaced when the pressure differential across the filter exceeds 70 kPa (10 psig, 0.7 bar).

**Service**

**Caution:** SHUT OFF AIR SUPPLY and exhaust the primary and secondary pressure before dis-assembling unit. (Units may be serviced without removing them from the air line.)

**Servicing Filter Element**

1. Unscrew threaded bowl and element holder. Then remove filter element, deflector, and gaskets.
2. Clean all internal parts, bowl, and body before re-assembling unit. See Polycarbonate bowl cleaning section.
3. Install deflector, filter element, and gaskets.
4. Attach element holder. Torque from 0.9 to 1.4 Nm (8 to 12 in-lbs).
5. To assist with retaining bowl's o-ring while installing bowl, lubricate the o-ring (with a mineral based oil or grease). Then place on the bowl.
6. Screw bowl into the body until it is stopped by body; then back off bowl 1/8 turn.
7. Apply pressure to the system and check for leaks. If leaks occur,

shut off the air supply, de-pressurize the system and make necessary adjustments to eliminate leakage.

If you have questions concerning how to service this unit, contact your local dealer or your customer service representative.

**Service Kits- Filter**

Kit#	Description
PS404	Polycarbonate Bowl with Manual Drain - consists of items: 19, 24, 26 & 27
PS408	Polycarbonate Bowl with Automatic Drain - consists of items: 19, 24, 26, 28, 29, 30 & 31
PS447B	Metal Bowl with Manual Drain - consists of items: 19, 24, 26 & 27
PS451	Metal Bowl with Automatic Drain - consists of items: 19, 24, 26, 28, 29, 30 & 31
PS403	5 Micrometer Element Kit - consists of items: 20, 21 & 24
PS407	5 Micrometer Element <u>Cartridge</u> Kit - consists of items: 20, 21, 22, 23 & 24
PS401	40 Micrometer Element Kit - consists of items: 20, 21 & 24

**Parts Identification List - Filter Units**

Item#	Description	Item#	Description
19	Bowl	26	O-ring (drain to bowl)
20	Gasket	27	Manual Drain (twist style)
21	Filter Element	28	O-ring - pulse drain
22	Filter Holder	29	Drain (body of pulse drain shown)
23	Deflector		
24	O-ring (body to bowl)	30	Diaphragm
25	Body	31	Pin

**Safety: Transparent Bowls**

**Caution**

Polycarbonate bowls, being transparent and tough, are ideal for use with Filters and Lubricators. They are suitable for use in normal industrial environments, but should not be located in areas where they could be subjected to direct sunlight, an impact blow, or temperatures outside of the rated range. As with most plastics, some chemicals can cause damage. Polycarbonate bowls should not be exposed to chlorinated hydro-carbons, ketones, esters, and certain alcohols. They should not be used in air systems where compressors are lubricated with fire-resistant fluids such as phosphate ester and di-ester types.

Metal bowls are recommended where ambient and/or media conditions are not compatible with Polycarbonate bowls. Metal bowls resist the action of most solvents, but should not be used where strong acids or bases are present or in salt laden atmospheres. Consult the factory for specific recommendations where these conditions exist.

**TO CLEAN POLYCARBONATE BOWLS, USE MILD SOAP AND WATER ONLY! DO NOT use cleansing agents such as acetone, benzene, carbon tetrachloride, gasoline, toluene, etc., which are damaging to this plastic.**

Metal bowls are recommended where ambient and/or media conditions are not compatible with polycarbonate bowls. If you have questions regarding bowl application, contact your customer service representative.

**WARNING**

To avoid Polycarbonate bowl rupture that can cause personal injury or property damage, do not exceed bowl pressure or temperature ratings. Polycarbonate bowls have a 1030 kPa (150 psig) pressure rating and a maximum temperature rating of 52°C (125°F).

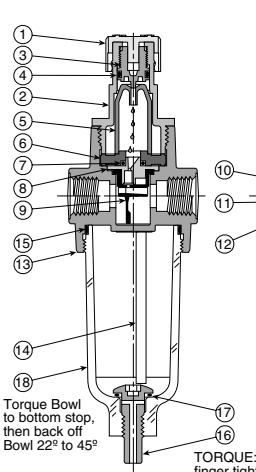

Figure 1: Mist Lubricator

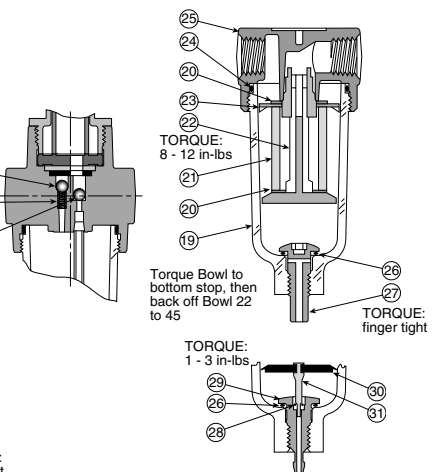

Figure 2: Particulate Filter